



HD-SDI output module

---

# **OM-595**

User's Manual

Ver.1.00





---

HD-SDI output module

---

**OM-595**

User's Manual

---

2005.10

Ver.1.00

ASTRODESIGN,Inc



# Table of Contents

Introduction .....	ii
Safety Precautions .....	ii
Avoid contact with foreign substances .....	ii
Do not disassemble .....	ii
Handling of the module .....	iii
In case of an abnormality or malfunction .....	iii
CHAPTER 1 About the OM-595 .....	1
1.1 Overview .....	1
1.2 Limitations to the specifications .....	2
CHAPTER 2 Names and Functions of Individual Components .....	3
2.1 OM-595 rear panel view and component names .....	3
CHAPTER 3 Connecting the Module .....	5
3.1 Connecting the output signal .....	5
CHAPTER 4 Adjustments and Settings .....	7
4.1 Menu structure .....	7
4.1.1 MENU mode .....	8
4.1.2 OUTPUT mode .....	10
4.2 Setting parameters .....	11
4.2.1 Setting the output timing .....	11
4.2.2 Adjusting the image quality .....	11
4.2.3 Setting the test pattern .....	11
CHAPTER 5 Timing Table List .....	13
5.1 Output timing table .....	13
5.2 Reference timing table .....	14
CHAPTER 6 Main Specifications .....	15
6.1 Specifications .....	15
6.2 Accessory .....	15
6.3 Outline drawing .....	16

## Introduction

Thank you for purchasing the OM-595/HD-SDI output module.

This document describes the functions and operating method of the OM-595, as well as the precautions to observe when using it.

Be sure to read this document before using the OM-595 since improper use may result in accidents.

After reading, please retain this document in a safe place for future reference.

## Safety Precautions

### **Warning**

#### **Avoid contact with foreign substances**

- **Do not spill liquid or drop a flammable substance or metal inside the module. Usage under such conditions may result in fire, electrical shock, or malfunction.**

#### **Do not disassemble**

- **Do not attempt to disassemble this module. To avoid the risk of electrical shock or injury to the user, or malfunction of the module, do not open the case or remove/reinstall the internal board.**

## **Caution**

### **Handling of the module**

- **The module consists of precision components; handle it with extreme care.**
- **To avoid the risk of electrical shock, injury, or malfunction, do not remove or add a module while the power is on.**
- **When removing the module, be careful to avoid brushing your hand against the connectors.**
- **Avoid mechanical shock and impact The module is a precision instrument that may be damaged by mechanical shock and impact. Be extremely careful when transporting the module.**
- **Do not drop the module.**

### **In case of an abnormality or malfunction**

- **If an abnormality or malfunction occurs, unplug the power cord and then contact your local dealer or the ASTRODESIGN sales group.**





# 1

## About the OM-595

---

### 1.1 Overview

- The OM-595 is an HD-SDI output module that can be installed in the SC-2055 Series (2 inputs, 2 outputs).
- Equipped with connectors for HD-SDI output (2CH) and external sync input (1CH) (75Ω auto-terminated/ loop-through OUT)
- The external sync supports HDTV2 and HDTV3 values, and BBS signal input.
- Outputs SMPTE-292M-compliant serial digital signals

## 1.2 Limitations to the specifications

The SC-2055 does have certain limitations and if they are exceeded, some distortion may occur in the images on the output screen.

Because there are also some limitations to the functionality, please take appropriate precautions when using the device.

### (1) External Sync Signal

If the external sync signal that is input does not contain a serration pulse, a correct lock will not be achieved, even if the front LED indicates a locked state.

If a signal of poor quality, such as from a VCR, or a signal that fluctuates by more than  $\pm 50\text{ppm}$  from the standard value is input, a correct lock may not be achieved in some cases.

Because the external reference signal is input as an analog signal, depending on that input signal, the output signal may exhibit a phase difference of several dots.

### (2) Lock Range

If the I/O vertical frequency ratio is 1:1, 1:2, 2:5 or 4:5, frame-lock operation is possible. With frame-lock operation, if the input and output timings are the same when the lock operation is implemented, the phase difference will always be the same. However, if the timings are not the same, a phase difference of approximately 2H (max) may occur each time the lock operation is implemented. (The phase of the lock may be adjusted to coordinate the timings.)

# 2

## Names and Functions of Individual Components

### 2.1 OM-595 rear panel view and component names

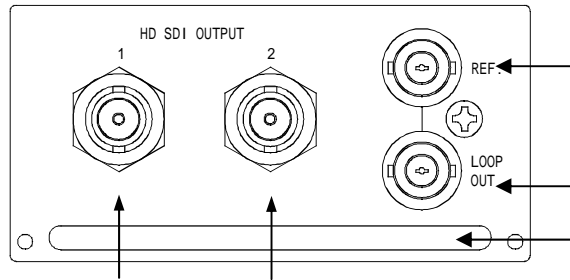

Fig. 2.1 OM-595 Rear Panel View

Table 2.1 Names of Rear Panel Components

No.	Name	Explanation
□	HD-SDI output connector	HD-SDI output connector (BNC connectors)
□		
□	REF input connector	External reference sync input connector (BNC connector)
□	LOOP OUT output connector	Loop-through output connector (BNC connector)
□	Handle	Used when inserting or removing the module



# 3

## Connecting the Module

### 3.1 Connecting the output signal

As shown in the figure, appropriately connect the HD-SDI output signal from the OM-595's output connector to a peripheral device.

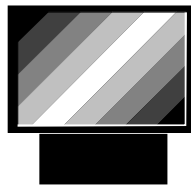

Projector

To the HD-SDI pin of a  
peripheral device

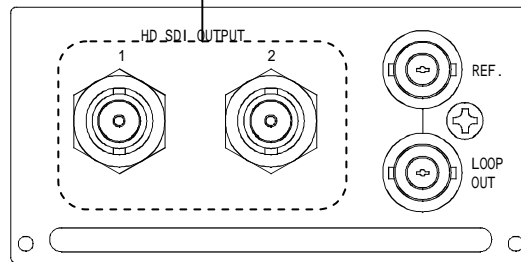







# 4

## Adjustments and Settings

### 4.1 Menu structure

From the default screen, push the rotary encoder to enter the menu structure described below.  
For the operation method, see the SC-2055 User's Manual.

Symbols are defined below.

 	PUSH operation
 	Rotate operation

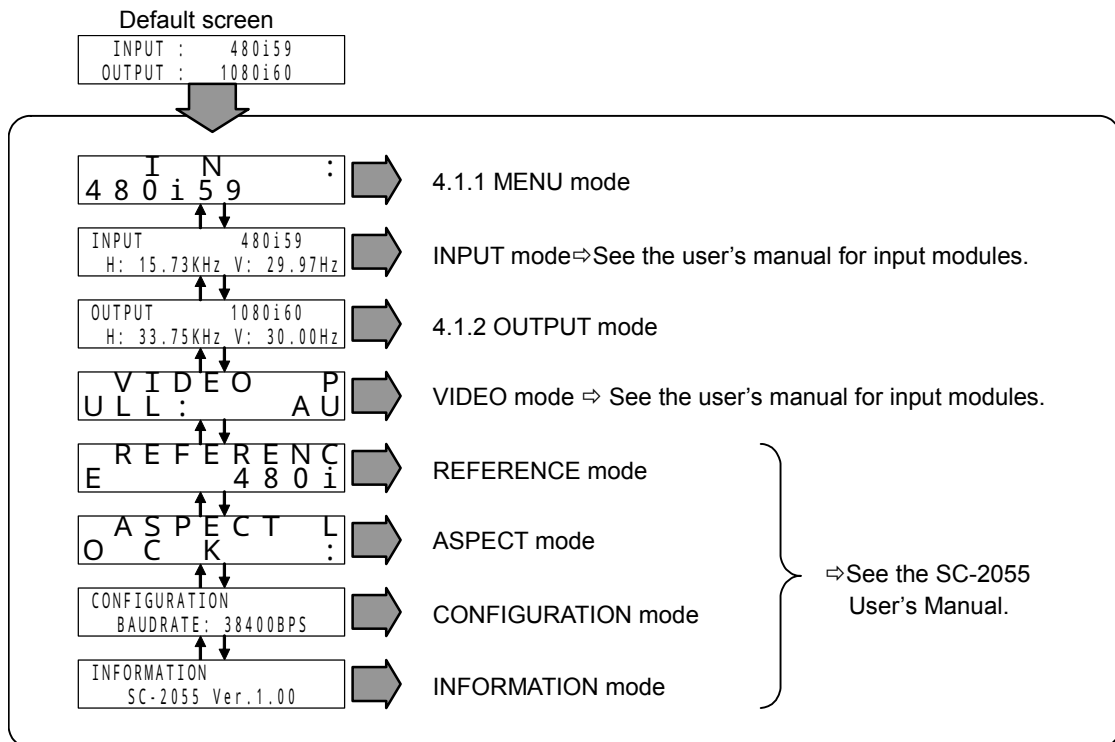

### 4.1.1 MENU mode

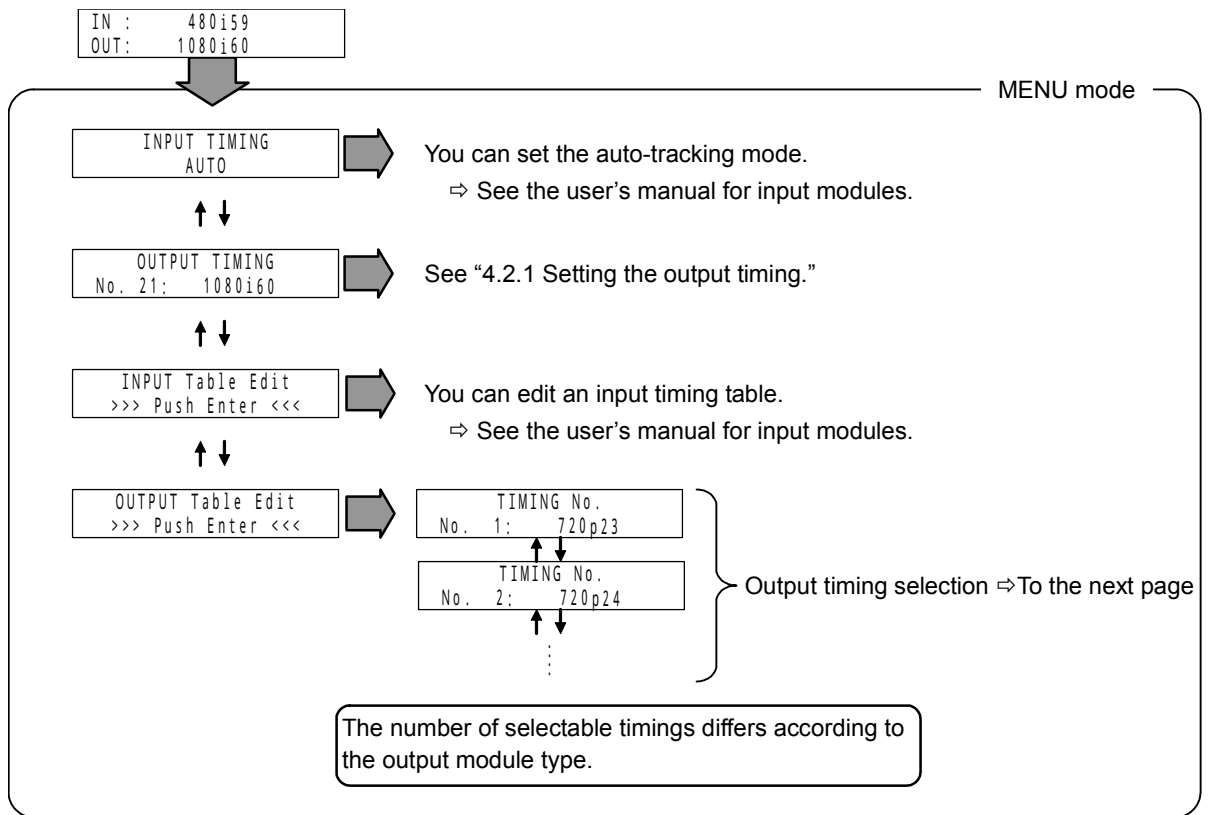



## Output timing selection

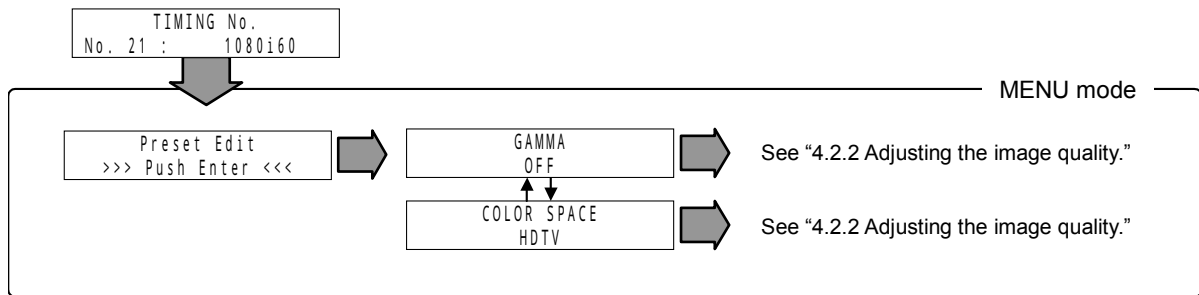

## 4.1.2 OUTPUT mode

The default screen of the OUTPUT mode displays the selected output timing.

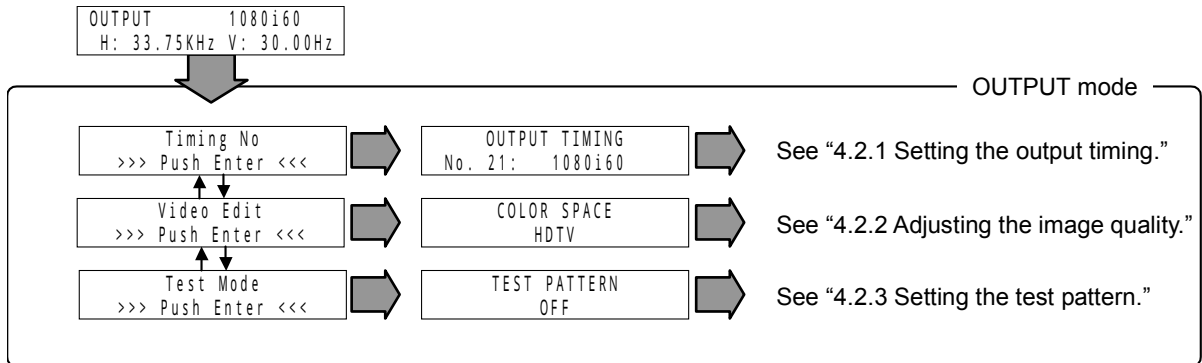

## 4.2 Setting parameters

### 4.2.1 Setting the output timing

Sets the output timing.

Parameter	Description	Setting value	Comments
OUTPUT TIMING	Output timing	Timing name*1	Changes the output timing.

\*1: The number of timing names that can be selected differs depending on the output module type.

### 4.2.2 Adjusting the image quality

Adjusts the image quality and sets parameters related to video display.

Parameter	Description	Setting Value	Comments
GAMMA	Gamma	OFF/ USER1/USER2	Sets the gamma mode.
COLOR SPACE	Color space setting	SDTV/HDTV1035/ HDTV	Sets the color space.

### 4.2.3 Setting the test pattern

Outputs a test pattern. Use this function for adjusting the display device.

Parameter	Description	Comments
TEST PATTERN	OFF	Normal screen display
	BRIGHT	Step-up pattern with black as the reference
	CONTRAST	Step-down pattern with white as the reference
	HUE&COLOR	Color signal RGB pattern in which the white level is attenuated to 75% and the black level is attenuated to 25%
	COLORBAR	100% colorbar display
	CROSSHATCH	1 dot, 1 line crosshatch pattern
	BURST	White/ black horizontal 1-dot repeated pattern
	FRAME	Frame display for the full video display interval
	WHITE	Displays WHITE on the entire screen
	RED	Displays RED on the entire screen
	GREEN	Displays GREEN on the entire screen
BLUE	Displays BLUE on the entire screen	



# 5

## Timing Table List

### 5.1 Output timing table

No	Name	Clock (MHz)	H period (dot)	H disp (dot)	H sync (dot)	H bp (dot)	V total (line)	V disp (line)	V sync (line)	V bp (line)	Scan
1	720p23	74.25 /1.001	4125	1280	40	260	750	720	5	20	Progressive
2	720p24	74.25	4125	1280	40	260	750	720	5	20	Progressive
3	720p25	74.25	3960	1280	40	260	750	720	5	20	Progressive
4	720p29	74.25 /1.001	3300	1280	40	260	750	720	5	20	Progressive
5	720p30	74.25	3300	1280	40	260	750	720	5	20	Progressive
6	720p50	74.25	1980	1280	40	260	750	720	5	20	Progressive
7	720p59	74.25 /1.001	1650	1280	40	260	750	720	5	20	Progressive
8	720p60	74.25	1650	1280	40	260	750	720	5	20	Progressive
9	1080p23	74.25 /1.001	2750	1920	44	192	1125	1080	5	36	Progressive
10	1080p24	74.25	2750	1920	44	192	1125	1080	5	36	Progressive
11	1080p25	74.25	2640	1920	44	192	1125	1080	5	36	Progressive
12	1080p29	74.25 /1.001	2200	1920	44	192	1125	1080	5	36	Progressive
13	1080p30	74.25	2200	1920	44	192	1125	1080	5	36	Progressive
14	1080i50	74.25	2640	1920	44	192	1125	1080	10	30	Interlace
15	1080i59	74.25 /1.001	2200	1920	44	192	1125	1080	10	30	Interlace
16	1080i60	74.25	2200	1920	44	192	1125	1080	10	30	Interlace
17	1035i59	74.25 /1.001	2200	1920	44	192	1125	1035	10	69	Interlace
18	1035i60	74.25	2200	1920	44	192	1125	1035	10	69	Interlace
19	1080sF23	74.25 /1.001	2750	1920	44	192	1125	1080	10	30	Progressive (sF)
20	1080sF24	74.25	2750	1920	44	192	1125	1080	10	30	Progressive (sF)
21	1080sF25	74.25	2640	1920	44	192	1125	1080	10	30	Progressive (sF)
22	1080sF29	74.25 /1.001	2200	1920	44	192	1125	1080	10	30	Progressive (sF)
23	1080sF30	74.25	2200	1920	44	192	1125	1080	10	30	Progressive (sF)

## 5.2 Reference timing table

No	Name	Clock (MHz)	H period (dot)	H disp (dot)	H sync (dot)	H bp (dot)	V total (line)	V disp (line)	V sync (line)	V bp (line)	Scan
1	720p23	74.25 /1.001	4125	1280	40	260	750	720	5	20	Progressive
2	720p24	74.25	4125	1280	40	260	750	720	5	20	Progressive
3	720p25	74.25	3960	1280	40	260	750	720	5	20	Progressive
4	720p29	74.25 /1.001	3300	1280	40	260	750	720	5	20	Progressive
5	720p30	74.25	3300	1280	40	260	750	720	5	20	Progressive
6	720p50	74.25	1980	1280	40	260	750	720	5	20	Progressive
7	720p59	74.25 /1.001	1650	1280	40	260	750	720	5	20	Progressive
8	720p60	74.25	1650	1280	40	260	750	720	5	20	Progressive
9	1080p23	74.25 /1.001	2750	1920	44	192	1125	1080	5	36	Progressive
10	1080p24	74.25	2750	1920	44	192	1125	1080	5	36	Progressive
11	1080p25	74.25	2640	1920	44	192	1125	1080	5	36	Progressive
12	1080p29	74.25 /1.001	2200	1920	44	192	1125	1080	5	36	Progressive
13	1080p30	74.25	2200	1920	44	192	1125	1080	5	36	Progressive
14	1080i50	74.25	2640	1920	44	192	1125	1080	10	30	Interlace
15	1080i59	74.25 /1.001	2200	1920	44	192	1125	1080	10	30	Interlace
16	1080i60	74.25	2200	1920	44	192	1125	1080	10	30	Interlace
17	1035i59	74.25 /1.001	2200	1920	44	192	1125	1035	10	69	Interlace
18	1035i60	74.25	2200	1920	44	192	1125	1035	10	69	Interlace
19	1080sF23	74.25 /1.001	2750	1920	44	192	1125	1080	10	30	Progressive (sF)
20	1080sF24	74.25	2750	1920	44	192	1125	1080	10	30	Progressive (sF)
21	1080sF25	74.25	2640	1920	44	192	1125	1080	10	30	Progressive (sF)
22	1080sF29	74.25 /1.001	2200	1920	44	192	1125	1080	10	30	Progressive (sF)
23	1080sF30	74.25	2200	1920	44	192	1125	1080	10	30	Progressive (sF)
24	480i59	13.5	858	720	63	59	525	483	6	30	Interlace
25	576i50	13.5	864	720	63	69	625	576	5	39	Interlace

# 6

## Main Specifications

### 6.1 Specifications

Table 6.1 OM-595 specifications

Item		Specification
Supported standard		SMPTE-292M
Timing		1920×1035×60/59.94i 1920×1080×60/59.94i 1920×1080×50i 1920×1080×30/29.97p 1920×1080×30/29.97sF 1920×1080×25p 1920×1080×25sF 1920×1080×24/23.98p 1920×1080×24/23.98sF 1280× 720×60/59.94p 1280× 720×50p 1280× 720×30/29.97p 1280× 720×25p 1280× 720×24/23.98p
Color format		YpbPr (SMPTE240M, SMPTE274M, SMPTE296M)/ 4:2:2
Image data resolution		10 bits
Number of channels		1 (BNC)
External sync	CS (BBS)	HDTV2 value (0.3Vpp/75Ω termination) HDTV3 value (±0.3Vpp/75Ω termination) Black burst signal (0.3Vpp/75Ω termination) (NTSC horizontal frequency = 13.5MHz/858) (PAL horizontal frequency = 13.5MHz/864)
	Number of input channels	1 (BNC)
	Loop-through output	Yes

### 6.2 Accessory

User's Manual	1 copy
---------------	--------

## 6.3 Outline drawing

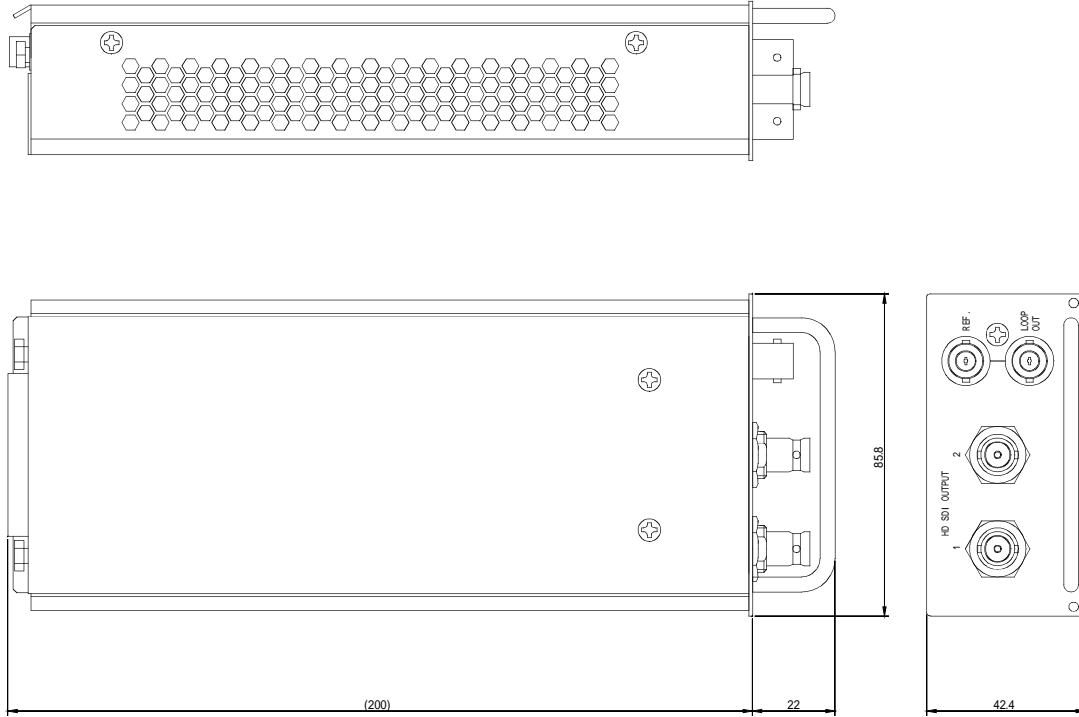



**Notes:**

Documents with missing or incorrectly collated pages will be replaced.

The copyright of this product belongs to ASTRODESIGN, Inc.

No part of this document may be used or reproduced without permission.

The contents of this document are subject to revision without notice.

ASTRODESIGN shall not be responsible for any damages resulting from misuse.

For additional information relating to this product, contact your local dealer or ASTRODESIGN at the address listed below.

All other products or product names listed in this document are trademarks or registered trademarks of their respective companies.

**T0066**

---

**ASTRODESIGN, INC.****URL <http://WWW.astrodesign.co.jp>**

First Sales Division  
2-6-17 Haramachi, Meguro-ku, Tokyo, Japan 152-0011  
Tel: (03) 5720-5838, Fax: (03) 5720-6353

Osaka Sales Office  
1-18-27-1010 Higashi-Nakajima, Higashi-Yodogawa-ku,  
Osaka, Japan 533-0033  
Tel: (06) 6328-8558, Fax: (06) 6328-5058